



**SANDUSKY CITY COMMISSION
REGULAR SESSION AGENDA
May 23, 2016 at 5 p.m.
City Hall, 222 Meigs Street**

INVOCATION	Dave Waddington
PLEDGE OF ALLEGIANCE	
CALL TO ORDER	
ROLL CALL	G. Lockhart, D. Brady, W. Poole, D. Murray, D. Waddington, N. Lloyd & N. Twine
APPROVAL OF MINUTES	May 9, 2016
AUDIENCE PARTICIPATION	
PRESENTATIONS	Erin Cremean, Sandusky City Schools Global Internship program (Students: Stanley Gilbert III, Amanda Miles & Eleecia Chavarría) Marvin Ranaldson, Sandusky Transit System - Annual Update
COMMUNICATIONS	Motion to accept all communications submitted below
CURRENT BUSINESS	

TABLED 5.9.16

ITEM #1 - Submitted by Casey Sparks, Assistant Planner

AMENDMENT TO ZONING MAP FOR PROPERTIES NEAR 629 WASHINGTON STREET

Budgetary Information: There is no impact to the general fund.

ORDINANCE NO. _____: It is requested an ordinance be passed amending the official zone map of the City of Sandusky to rezone a portion of Parcel #56-01241.000, located at 629 Washington Street, from "R2F" Two-Family Residential district to "DB" Downtown Business district.

TABLED 5.9.16

ITEM #2 - Submitted by Casey Sparks, Assistant Planner

AMENDMENT TO ZONING MAP FOR SIXTEEN PARCELS

Budgetary Information: There is no impact to the general fund.

ORDINANCE NO. _____: It is requested an ordinance be passed amending the official zone map of the City of Sandusky to rezone sixteen (16) parcels from R1-40 Single-Family Residential district to "CR" Commercial Recreation district.

ITEM #3 – Submitted by Aaron Klein, Director of Public Works

Budgetary Information: There is no budgetary impact with this item and the licensee must maintain liability insurance for this use. The property owner is responsible for recording fees to the Erie County Recorder's Office.

ORDINANCE NO. _____: It is requested an ordinance be passed authorizing the City Manager to enter into a license agreement with Cattien, LLC, to provide for the use of a certain portion of the city's rights-of-way as described in the grant of a license for encroachment; and declaring that this ordinance shall take immediate effect in accordance with Section 14 of the city charter.

ITEM #4 – Submitted by Maria Muratori, Economic Development Specialist

Budgetary Information: The city will be responsible for providing \$24,000 in grant proceeds from the economic development capital projects fund.

ORDINANCE NO. _____: It is requested an ordinance be passed authorizing and approving a grant in the amount of \$24,000 to Sandusky Renaissance Properties, LLC, in relation to the property located at 217 East Water Street; and declaring that this ordinance shall take immediate effect in accordance with Section 14 of the city charter.

ITEM #5 – Submitted by Angela Byington, Director of Neighborhood Development & Planning

Budgetary Information: The project cost based on the bid, including advertisement and miscellaneous costs is \$22,400. The project will be paid with FY 2015 Community Development Block Grant funds.

ORDINANCE NO. _____: It is requested an ordinance be passed authorizing and directing the City Manager to enter into a contract with Premier Concrete of Norwalk, Ohio, for the CDBG FY 2015 residential demolition project #4; and declaring that this ordinance shall take immediate effect in accordance with Section 14 of the city charter.

ITEM #6 – Submitted by John Orzech, Police Chief

Budgetary Information: The total cost for a new L-3 Flashback HD digital cruiser video system and accessories is \$6,636.28. The grant will fund \$4,977.21 (75%) and the matching funds of \$1,659.07 (25%) will be paid with funds from the Police Department's operating budget. Due to the effects of the economy, the match portion may be waived and a request for a waiver for the match will be submitted with the application.

RESOLUTION NO. _____: It is requested a resolution be passed approving the submission of a grant application to the Ohio Office of Criminal Justice Services for funding through the FY 2016 Edward Byrne Memorial Justice Assistance grant program for the Sandusky Police Department; and declaring that this resolution shall take immediate effect in accordance with Section 14 of the city charter.

ITEM #7 – Submitted by Kelly Kresser, Commission Clerk

A request has been received from the Ohio Division of Liquor Control for a new D5J Liquor Permit (*spirituous liquor for on premises consumption only: beer, wine and mixed beverages for on premises, or off premises in original sealed containers, until 2:30 a.m. in a community entertainment district*) for Jami S. Tallman LTD, LLC dba Scarlett O'Hair Salon, 123 – 125 West Market Street. It is requested the Commission Clerk be authorized to notify the Ohio Division of Liquor Control the city has no objections to this request.

ITEM #8 – Submitted by Kelly Kresser, Commission Clerk

A request has been received from the Ohio Division of Liquor Control for a new D5J Liquor Permit (*spirituous liquor for on premises consumption only: beer, wine and mixed beverages for on premises, or off premises in original sealed containers, until 2:30 a.m. in a community entertainment district*) for McGookey Properties LLC dba Baithouse Brew Pub, 215 Meigs Street. It is requested the Commission Clerk be authorized to notify the Ohio Division of Liquor Control the city has no objections to this request.

CITY MANAGER'S REPORT

OLD BUSINESS

NEW BUSINESS

AUDIENCE PARTICIPATION Open discussion on any item (5 minute limit)

EXECUTIVE SESSION(S)

ADJOURNMENT

Buckeye CableSystem broadcasts on Cable Channel 76:

Monday, May 23 at 8:30 p.m.

Tuesday, May 24 at 5 p.m.

Monday, May 31 at 8:30 p.m.

YouTube: https://www.youtube.com/channel/UCBxZ482ZeTTixa_Rm16YWTQ



DEPARTMENT OF PUBLIC WORKS

AARON M. KLEIN, P.E.

222 Meigs Street
Sandusky, Ohio 44870
Phone 419/627-5829
Fax 419/627-5933
aklein@ci.sandusky.oh.us

To: Eric Wobser, City Manager
From: Aaron M. Klein, P.E.
Date: May 10, 2016
Subject: **Commission Agenda Item – 202 Columbus Ave Encroachment License**

ITEM FOR CONSIDERATION: Encroachment License for the property located at 202 Columbus Avenue for the installation of a decorative fence to enclose an outdoor dining area by Cattien, LLC operating as Small City Taphouse. A request for encroachment was received by the Department of Public Works on April 28, 2016.

BACKGROUND INFORMATION: The encroachment into the right of way is 378.48 square feet along Columbus Avenue. This license will grant the property owner of 202 Columbus Ave permission to install decorative fencing for the purpose of an outdoor dining area in the right-of-way for so long as the license complies with all requirements of this agreement and licensee acknowledges that this Grant of a Licensee is terminable at the will of the City.

Certificate of Appropriateness has been issued by the Downtown Design Review Committee and no objections were heard from the Building and Zoning Departments.

BUDGETARY INFORMATION: There is no budgetary impact with this item and the licensee must maintain liability insurance for this use. The property owner is responsible for recording fees to the Erie County Recorder Office.

ACTION REQUESTED: It is recommended that the Grant of a License for Encroachment within the Columbus Avenue right of way be approved for the business located at 202 Columbus Avenue and that the necessary legislation be passed under suspension of the rules in full accordance with Section 14 of the City Charter so the owner may construct the fence prior to Memorial Day weekend.

I concur with this recommendation:

Eric Wobser
City Manager

Aaron M. Klein
Director

cc: K. Kresser, Commission Clerk; H. Solowiej, Finance Director; J. Harris, Law Director

**City of Sandusky Department of Community Development
Downtown Design Review**



Certificate of Appropriateness

Applicant / Owner Information:

Property Owner Name, Address: Phuo Ngo
2810 Hull Road
Sandusky, Ohio 44870

Telephone & email: N/A

Authorized Agent Name, Address: Phuo Ngo
2810 Hull Road
Sandusky, Ohio 44870

Telephone & email: N/A

Location of Project (Municipal Street Address): 202 Columbus Ave

Perm Parcel # 56-00615.000

Project Description: Fencing for outdoor patio area

Conditions

Type of Approval:

- Application approved as submitted per Chapter 1359 of the Codified Ordinances of the City of Sandusky.
- Application approved contingent on administrative conditions per Downtown Design Review Process.
- Application not approved as submitted.

Permits required (the following permits must be obtained before work proceeds)

___ Sign permit ___ Building permit ___ Fence permit ___ (other) Zoning Permit



Casey Sparks
Assistant Planner

5/10/16
Date

ORDINANCE NO. _____

AN ORDINANCE AUTHORIZING THE CITY MANAGER TO ENTER INTO A LICENSE AGREEMENT WITH CATTIEN, LLC, TO PROVIDE FOR THE USE OF A CERTAIN PORTION OF THE CITY'S RIGHTS-OF-WAY AS DESCRIBED IN THE GRANT OF A LICENSE FOR ENCROACHMENT; AND DECLARING THAT THIS ORDINANCE SHALL TAKE IMMEDIATE EFFECT IN ACCORDANCE WITH SECTION 14 OF THE CITY CHARTER.

WHEREAS, certain property of the City is currently platted as City right-of-way including the property identified and more fully described in Exhibit "A"; and

WHEREAS, this proposed License for Encroachment will allow the property owner, Cattien, LLC, operating as Small City Taphouse, to install a decorative fence to accommodate outdoor dining; and

WHEREAS, a Certificate of Appropriateness has been issued by the Downtown Design Review Committee and the City's Building Department and Zoning Department have reviewed the request and do not object; and

WHEREAS, this City Commission, under powers of Local self-government granted to the City by Article XVIII of the Ohio Constitution and Section 3 and Section 25 of the Charter of the City of Sandusky, has the power to change the use of City property to a use that would be of greater benefit and use to the public; and

WHEREAS, this Ordinance should be passed as an emergency measure under suspension of the rules in accordance with Section 14 of the City Charter in order to execute the Grant of a License for Encroachment and allow the property owner to construct the fence prior to Memorial Day weekend; and

WHEREAS, in that it is deemed necessary in order to provide for the immediate preservation of the public peace, property, health, and safety of the City of Sandusky, Ohio, and its citizens, and to provide for the efficient daily operation of the Municipal Departments, including the Department of Public Works, of the City of Sandusky, Ohio, the City Commission of the City of Sandusky, Ohio finds that an emergency exists regarding the aforesaid, and that it is advisable that this **Ordinance** be declared an emergency measure which will take immediate effect in accordance with Section 14 of the City Charter upon its adoption; and **NOW, THEREFORE**,

BE IT ORDAINED BY THE CITY COMMISSION OF THE CITY OF SANDUSKY, OHIO, THAT:

Section 1. The City Manager is authorized and directed to enter into the Grant of a License for Encroachment Agreement with Cattien, LLC, operating as Small City Taphouse, substantially in the same form as contained in Exhibit "1", which is attached to this Ordinance and is specifically incorporated as if fully rewritten herein together with such revisions or additions as are approved by the Law Director as not being adverse to the City and as being consistent with carrying out the City's public purpose as set forth in the preamble hereto.

Section 2. If any section, phrase, sentence, or portion of this Ordinance is for any reason held invalid or unconstitutional by any Court of competent jurisdiction, such portion shall be deemed a separate, distinct, and independent provision, and such holding shall not affect the validity of the remaining portions thereof.

Section 3. This City Commission finds and determines that all formal actions of this City

Commission concerning and relating to the passage of this Ordinance were taken in an open meeting of this City Commission and that all deliberations of this City Commission and of any of its committees that resulted in those formal actions were in meetings open to the public in compliance with the law.

Section 4. That for the reasons set forth in the preamble hereto, this Ordinance is hereby declared to be an emergency measure which shall take immediate effect in accordance with Section 14 of the City Charter after its adoption and due authentication by the President and the Clerk of the City Commission of the City of Sandusky, Ohio.

DENNIS E. MURRAY, JR.
PRESIDENT OF THE CITY COMMISSION

ATTEST:

KELLY L. KRESSER
CLERK OF THE CITY COMMISSION

Passed: May 23, 2016

**GRANT OF A LICENSE FOR ENCROACHMENT
ON THE EAST SIDE OF COLUMBUS AVENUE
& SOUTH SIDE OF MARKET STREET RIGHT-OF-WAY**

This License Agreement is made this ____ day of _____, 2016, between the City of Sandusky, Ohio ("City") whose tax mailing address is 222 Meigs Street, Sandusky, Erie County, Ohio, 44870, and Cattien, LLC, ("Licensee") whose tax mailing address is 202 Columbus Avenue, Sandusky, Erie County, Ohio, 44870, under the following conditions and circumstances:

A. The City of Sandusky, Erie County, Ohio, is the Owner and Trustee for the general public of the rights-of-way as defined in the Ohio Revised Code, Section 4511.01(uu), including Columbus Avenue, and is more fully described in Exhibit "A" which is attached to this License Agreement and is specifically incorporated as if fully rewritten herein.

B. Licensee is the owner in fee simple of the real estate adjoining the east side of the Columbus Avenue right-of-way located at 202 Columbus Avenue.

C. Licensee desires to construct improvements within the Owner's right-of-way for purposes of installing a decorative fence to accommodate outdoor dining for use by the general public and in relation to the Licensee's facility located at 202 Columbus Avenue, Sandusky, Ohio, and as more fully described in Exhibits "A", and "B" which are attached to this License Agreement and are specifically incorporated as if fully rewritten herein.

D. The City is willing to grant to Licensee a temporary license to maintain the encroachment for so long as Licensee remains the owner of the

property to the east side of the Columbus Avenue right-of-way and provided the encroachment is not substantially altered.

NOW, THEREFORE, FOR GOOD AND VALUABLE CONSIDERATION PAID, THE PARTIES AGREE AS FOLLOWS:

1. The City grants to Licensee the license and permission to construct and maintain the encroachment as more fully described in Exhibits "A", and "B" which are attached to this License Agreement and are specifically incorporated as if fully rewritten herein, for so long as Licensee remains the owner of real property located at 202 Columbus Avenue, Sandusky, Ohio, and provided that the encroachment is not substantially altered and Licensee complies with all legal requirements and Licensee acknowledges that this grant of a license is terminable at the will of the City;

2. Licensee agrees that, except for the license granted pursuant to this Agreement, Licensee makes no claim of right and has no interest or title in any part of the property and Licensee further agrees that the maintenance of the encroachment shall not, at any time, be deemed or construed to be an adverse possession of any part of the City's right-of-way;

3. Licensee agrees to construct and maintain the encroachment, solely at Licensee's expense, for use in conjunction with Licensee's facilities located at 202 Columbus Avenue, Sandusky, Ohio, and further agrees to indemnify and hold harmless the City of Sandusky (it's officials, employees, boards, commissions and agents) from any and all loss, damage, expense, or liability arising from the maintenance of the encroachment;

4. This Agreement shall not be construed to run with the land and is only a temporary license, terminable at the will of the Owner.

SIGNATURE PAGES TO FOLLOW

IN WITNESS WHEREOF, the parties have hereunto set their hands on the dates indicated below:

SIGNED AND ACKNOWLEDGED
IN THE PRESENCE OF:

CITY:
CITY OF SANDUSKY

Eric L. Wobser, City Manager

State of Ohio)
) ss:
County of Erie)

Before me a Notary Public for the State of Ohio, appeared the above named, Eric L. Wobser, City Manager of the City of Sandusky, who acknowledged that he signed the foregoing instrument and that the signing was a free act.

IN TESTIMONY WHEREOF, I have hereto subscribed my name and affixed my seal this _____ day of _____, 2016.

Notary Public
My Commission Expires:

SIGNED AND ACKNOWLEDGED
IN THE PRESENCE OF:

LICENSEE: CATTIEN, LLC

(Signature)

(Printed Name & Title)

State of Ohio)
) ss:
County of Erie)

Before me a Notary Public for the State of Ohio, appeared the above named, _____, who acknowledged that they signed the foregoing instrument and that the signing was a free act.

IN TESTIMONY WHEREOF, I have hereto subscribed my name and affixed my seal this _____ day of _____, 2016.

Notary Public
My Commission Expires:

Instrument prepared by:

Trevor M. Hayberger
Ohio Supreme Court #0075112
Assistant Law Director
City of Sandusky

ENCROACHMENT LICENSE AGREEMENT
202 Columbus Avenue
378.48 S.F.

Situate in the State of Ohio, County of Erie, City of Sandusky, Ward 1, and being part of the easterly right-of-way of Columbus Avenue (99 feet in width) adjoining Lot 8 Columbus Avenue, all references herein to the records of the Erie County Recorder's Office, more particularly described as follows:

Beginning, for reference, at an iron pin found in a monument box marking the intersection of centerlines of Water Street and Columbus Avenue; thence, South 25°29'21" East with the centerline of Columbus Avenue, a distance of 469.57 feet to a point being 41.25 feet southerly of the intersection of centerlines of Market Street (82.5 feet in width) and Columbus Avenue; thence, North 64°20'20" East through the easterly right-of-way of Columbus Avenue, a distance of 41.90 feet to a point and the **True Point of Beginning** for this description;

Thence continuing, North 64°20'20" East through said right-of-way, a distance of 7.60 feet to a point at the intersection of right-of-way lines of Market Street and Columbus Avenue;

Thence, South 25°29'21" East along the easterly right-of-way line of Columbus Avenue and the westerly edge of a building, and with lands of Cattien, LLC, RN 201601898, a distance of 49.80 feet to a point;

Thence, South 64°20'20" West through said right-of-way, a distance of 7.60 feet to a point;

Thence, North 25°29'21" West through said right-of-way, a distance of 49.80 feet the point of beginning, containing 378.48 square feet of land, more or less, subject to an easement for operation and maintenance of existing utilities.

This description was prepared by John Hancock, P.S. No. 6918 from a survey conducted in April, 2016. Bearings hereon are based upon an assumed bearing of South 25°29'21" East for the centerline of Columbus Avenue.

John Hancock & Associates, Inc.

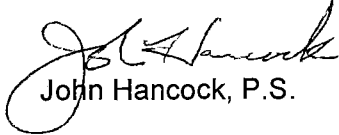
John Hancock, P.S.

Date: APRIL 19, 2016

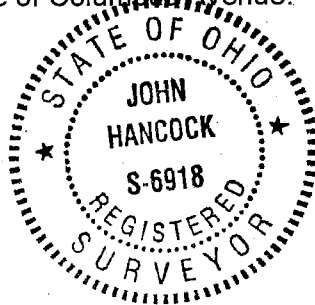

REVISED:

John Hancock & Associates
INCORPORATED
ENGINEERS - SURVEYORS
326 E. MARKET ST. SANDUSKY, OHIO 44870
(419) 625-7638

ENCROACHMENT LICENSE AGREEMENT
202 COLUMBUS AVENUE
EASTERLY SIDE OF COLUMBUS AVENUE RIGHT-OF-WAY
WARD 1, CITY OF SANDUSKY, ERIE COUNTY, OHIO

JOB NO.:	243316
DRN BY:	DMM
FILE NO.:	2433-SURV
DATE:	4/19/16
SCALE:	1" = 10'
SHEET NO.:	1

202 COLUMBUS AVENUE
CATTIEN, LLC
RN 201601898
56-00615.000

PARCEL 2

8

PARCEL 1

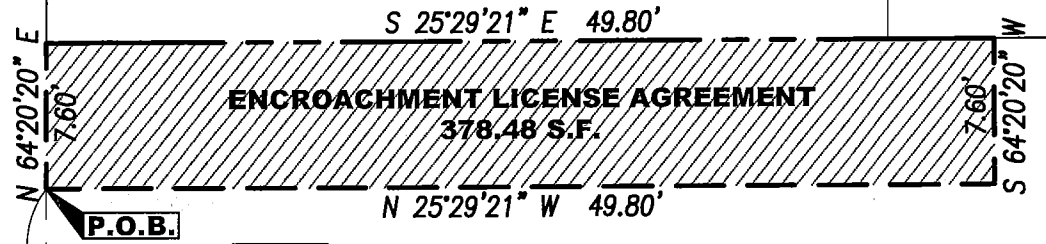

ENCROACHMENT LICENSE AGREEMENT
378.48 S.F.

P.O.B.

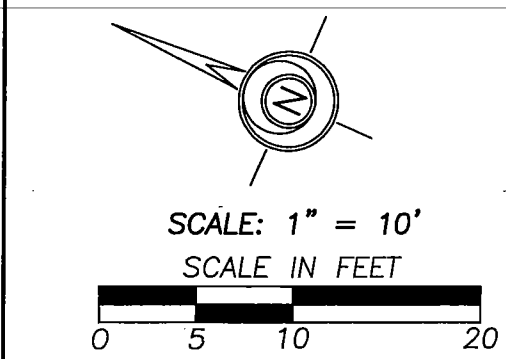

MARKET STREET
(82.5' RIGHT-OF-WAY)

WATER STREET

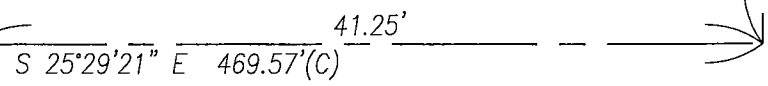
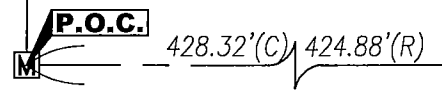

COLUMBUS AVENUE
(99' RIGHT-OF-WAY)

N 64°20'20" E 41.90'

BEARINGS HEREON ARE BASED UPON AN ASSUMED BEARING OF S 25°29'21" E FOR THE CENTERLINE OF COLUMBUS AVENUE

I HEREBY CERTIFY THAT THIS PLAT WAS PREPARED FROM AN ACTUAL FIELD SURVEY OF THE PREMISES CONDUCTED BY ME PURSUANT TO CHAPTER 4733-37 OF THE OHIO ADMINISTRATIVE CODE.

John Hancock
JOHN HANCOCK, P.S.
OHIO R.L.S. 6918
DATE: APRIL 19, 2016

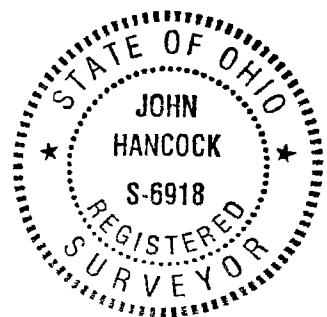

JACKSON STREET

RR SPK FND.

- LEGEND:**
- (C) CALCULATED DISTANCE
 - ☒ 1" IRON PIN FOUND IN A MONUMENT BOX
 - MONUMENT FOUND (AS NOTED)



Department of Community Development

Maria Muratori
mmuratori@ci.sandusky.oh.us

222 Meigs St.
Sandusky, OH 44870
Phone: 419.627.5891
www.ci.sandusky.oh.us

To: Eric L. Wobser, City Manager

From: Maria Muratori, Economic Development Specialist

Date: May 10, 2016

Subject: Commission Agenda Item – Grant Agreement between City of Sandusky and Sandusky Renaissance Properties, LLC

Items for Consideration: Legislation approving a Grant Agreement to be entered into between the City of Sandusky and Sandusky Renaissance Properties, LLC (“SRP”), an Ohio Limited Liability Company, for the purposes of furthering economic development efforts in the City.

Background Information: Sandusky Renaissance Properties, LLC is seeking to eliminate blight and continue to improve the 200 block of E. Water Street in terms of visual perspective and commercial relevance. Mr. Robert Hare, the managing member of SRP, has orchestrated the financing, renovation, and leasing of the current location of Hearth Tavern and ZINC Brasserie at 213/215 E. Water Street. 217 E. Water Street is the third “bay” of the 213/215/217 E. Water Street properties that is now ready for renovation. Until the properties were purchased by SRP in 2012, they were vacant and blighted. The purchase and renovations to date have been performed with owner capital and commercial financing. SRP is requesting assistance to complete the final step.

Specifically, the owners of Hearth and ZINC will expand operations into 217 E. Water Street. The new space will include a first floor and lower level private dining hall/banquet/meeting space at the rear of 217 E. Water. The business operators (Cesare and Andrea Avallone) will also open a new operation at the front of the space that will provide breakfast and lunch along with a small seating area. The Avallone’s are established business operators, evidenced by their existing establishments (Hearth Tavern, ZINC Brasserie, and Dockside). In order to properly renovate the property, both front and back facades will require significant improvement, including the removal of the historical truck dock and ramp, enabling a new entrance at street level on Shoreline Drive.

The total project cost is estimated at approximately \$130,000, \$40,000 of which relates specifically to the façade – including roof repair, front and rear façade improvements, and other exterior site improvements. I recommend that the City Commission approve a grant for \$24,000, which is 60% of costs related to the comprehensive façade renovation.

This application and grant amount was approved at the March 8, 2016 Economic Development Review Committee meeting, in accordance with the Sandusky City Economic Development Programs.

Budgetary Information: The City will be responsible for providing \$24,000 in grant proceeds from the Economic Development Capital Projects Fund.

Action Requested: It is requested that the proper legislation be prepared to allow the City to enter into a Grant Agreement with Sandusky Renaissance Properties, LLC. It is further requested that this legislation be passed in accordance with Section 14 of the City Charter to expedite passage in order to facilitate rehabilitation.

I concur with this recommendation:

Eric L. Wobser
City Manager

Maria Muratori
Economic Development Specialist

Matthew D. Lasko, MUPDD, MSSA
Chief Development Officer

cc: Kelly Kresser, Clerk of the City Commission
Justin Harris, Law Director
Trevor Hayberger, Assistant Law Director
Hank Solowiej, Finance Director
Angela Byington, Planning Director

ORDINANCE NO. _____

AN ORDINANCE AUTHORIZING AND APPROVING A GRANT IN THE AMOUNT OF \$24,000.00 TO SANDUSKY RENAISSANCE PROPERTIES, LLC, IN RELATION TO THE PROPERTY LOCATED AT 217 E. WATER STREET; AND DECLARING THAT THIS ORDINANCE SHALL TAKE IMMEDIATE EFFECT IN ACCORDANCE WITH SECTION 14 OF THE CITY CHARTER.

WHEREAS, Sandusky Renaissance Properties, LLC, is planning to completely renovate the facility located at 217 E. Water Street with exterior and interior upgrades which is the third "bay" of the owners Water Street properties of which 213 and 215 E. Water Street have already been renovated and now the current location of Zinc and Hearth Tavern; and

WHEREAS, the owners of Zinc and Hearth plan to expand their operations into 217 E. Water Street which will include a first floor and lower level private dining hall / banquet / meeting space at the back and open a new retail operation at the front of the space that will provide breakfast and lunch; and

WHEREAS, Sandusky Renaissance Properties, LLC's project involves renovating both front and rear facades, including the removal of the historical truck dock and ramp, which will enable a new entrance at street level on Shoreline Drive and has requested financial assistance to complete the project; and

WHEREAS, the City has determined that the development of the Property with the Project pursuant to this Agreement and the fulfillment generally of this Agreement are in the vital and best interests of the City and for the health and safety and welfare of its residents, and are necessary to improve the economic and general welfare of people of the City; and

WHEREAS, the Economic Development Review Committee met on March 8, 2016, and is recommending to approve a grant to Sandusky Renaissance Properties, LLC, in the amount of \$24,000.00 for the purposes of furthering economic development within the City; and

WHEREAS, this Ordinance should be passed as an emergency measure under suspension of the rules in accordance with Section 14 of the City Charter in order to execute the Grant Agreement and facilitate rehabilitation; and

WHEREAS, in that it is deemed necessary in order to provide for the immediate preservation of the public peace, property, health, and safety of the City of Sandusky, Ohio, and its citizens, and to provide for the efficient daily operation of the Municipal Departments, including the Department of Community Development, of the City of Sandusky, Ohio, the City Commission of the City of Sandusky, Ohio finds that an emergency exists regarding the aforesaid, and that it is advisable that this **Ordinance** be declared an emergency measure which will take immediate effect in accordance with Section 14 of the City Charter upon its adoption; and NOW, THEREFORE,

BE IT ORDAINED BY THE CITY COMMISSION OF THE CITY OF SANDUSKY, OHIO, THAT:

Section 1. This City Commission authorizes and directs the City Manager to enter into a Grant Agreement with Sandusky Renaissance Properties, LLC, for the purposes of furthering economic development, substantially in the same form as Exhibit "A", a copy of which is attached to this Ordinance and is specifically incorporated as if fully rewritten herein, together with such revisions or additions as are approved by the Law Director as not being adverse to the City and as being consistent with carrying out the terms of this Ordinance.

Section 2. This City Commission authorizes and approves the grant funding to Sandusky Renaissance Properties, LLC, and the Finance Director is directed to deliver to Sandusky Renaissance Properties, LLC, a draft in the sum of Twenty Four Thousand and 00/100 Dollars

(\$24,000.00) from the Economic Development Capital Projects Fund of the City of Sandusky pursuant to and in accordance with the terms of the Grant Agreement.

Section 3. If any section, phrase, sentence, or portion of this Ordinance is for any reason held invalid or unconstitutional by any Court of competent jurisdiction, such portion shall be deemed a separate, distinct, and independent provision, and such holding shall not affect the validity of the remaining portions thereof;

Section 4. This City Commission finds and determines that all formal actions of this City Commission concerning and relating to the passage of this Ordinance were taken in an open meeting of this City Commission and that all deliberations of this City's Commission and any of its committees that resulted in those formal actions were in meetings open to the public, in compliance with all legal requirements;

Section 5. That for the reasons set forth in the preamble hereto, this Ordinance is hereby declared to be an emergency measure which shall take immediate effect in accordance with Section 14 of the City Charter after its adoption and due authentication by the President and the Clerk of the City Commission of the City of Sandusky, Ohio.

DENNIS E. MURRAY, JR.
PRESIDENT OF THE CITY COMMISSION

ATTEST:

KELLY L. KRESSER
CLERK OF THE CITY COMMISSION

Passed: May 23, 2016

GRANT AGREEMENT

This Grant Agreement (the "Agreement") is made and entered into as of the ____ day of _____, 2016 between the CITY OF SANDUSKY, OHIO (the "City"), a municipal corporation and political subdivision duly organized and validly existing under the Constitution, its Charter, and the laws of the State of Ohio, and Sandusky Renaissance Properties, LLC ("the Company"), an Ohio Limited Liability Company.

WITNESSETH:

WHEREAS, the Company plans to completely renovate its facility located at 217 E Water Street with exterior and interior upgrades. The location is the third "bay" of the 213/215/217 E Water Street properties, of which 213 and 215 E Water Street have already been renovated and are now the current location of Zinc and Hearth Tavern. Until the properties were purchased by SRP in 2012, they were vacant and blighted. The purchase and renovations to date have been performed with owner capital and commercial financing (\$275,000 not including the third bay). The owners of Zinc and Hearth will expand their operations into 217 E Water Street. The new space will include a first floor and lower level private dining hall/banquet/meeting space at the back of 217 E Water Street. The business operators will also open a new retail operation at the front of the space that will provide breakfast and lunch. The Company will renovate both front and rear facades, including the removal of the historical truck dock and ramp, which will enable a new entrance at street level on Shoreline Drive, herein after referred to as the "Project"; and

WHEREAS, to induce the Project, the City has agreed to provide an economic incentive grant to the Company to assist in the payment of a portion of the costs of the Project as further described in Section 1 hereof; and

WHEREAS, the City has determined that the development of the Property with the Project pursuant to this Agreement and the fulfillment generally of this Agreement are in the vital and best interests of the City and for the health and safety and welfare of its residents, and are necessary to improve the economic and general welfare of people of the City;

NOW THEREFORE, in consideration of the premises and the covenants contained herein, the parties hereto agree as follows:

Section 1. City Grant.

The City agrees to grant \$24,000 to the Company (the "City Grant") toward the costs of the Project, payable upon completion of construction. The City Grant will be expensed from the Economic Development Capital Projects account (#431-4070-53000). Construction must be done in accordance with and to the reasonable satisfaction of the City, which would include, but not limited to, compliance with all Planning and Zoning matters and other applicable codes and regulations of the City of Sandusky; and

The Company shall notify the City promptly following the completion of the construction consistent with this Section and provide the City with any documents it reasonably requests related to the construction. The City shall then promptly review those documents and inspect the

site and let the Company know if it has satisfied the condition set forth in this Section and, if not, describe what is found to be deficient.

The City shall pay the City Grant by check in the name of the Company placed in the U.S. regular mail within fourteen (14) days following confirmation of the satisfactory completion of construction to the notice address provided in Section 6 below.

Section 2. Authority to Sign.

The Company and the City both represent that this Agreement has been approved by formal action of the duly authorized representatives of both parties.

Section 3. Assignment or Transfer.

The Company agrees that this Agreement is not transferable or assignable without the express, written approval of the City.

Section 4. Choice of Law.

This Agreement shall be governed and interpreted in accordance with the laws of the State of Ohio and the parties hereto agree that any dispute or other matter arising out of the interpretation or operation of this Agreement shall be determined in a Court of competent jurisdiction located within the State of Ohio and County of Erie.

Section 5. Binding Agreement.

This Agreement shall be binding on each of the parties and their respective successors and assigns.

Section 6. Miscellaneous.

(a) Notice. Any notice or communication required or permitted to be given under this Agreement by either party to the other shall be deemed sufficiently given if delivered personally or mailed by United States registered or certified mail postage prepaid or by overnight delivery and addressed as follows:

- (i) TO THE CITY: City Manager
c/o Economic Development Specialist
City of Sandusky, Ohio
City Building
222 Meigs Street
Sandusky, OH 44870
- (ii) TO THE COMPANY: Sandusky Renaissance Properties, LLC
PO Box 1070
Sandusky, Ohio 44871-1070
Attention: Robert Hare

Any party may change its address for notice purposes by providing written notice of such change to the other party.

(b) Amendments. This Agreement may only be amended by written instrument executed by all parties.

(c) Effect of Agreement. This Agreement is signed by the parties as a final expression of all the terms, covenants and conditions of their agreement and as a complete and exclusive statement of its terms, covenants and conditions and is intended to supersede all prior agreements and understandings concerning the subject matter of this Agreement.

(d) Counterparts. This Agreement may be signed in several counterparts, each of which shall be an original, but all of which shall constitute but one and the same instrument.

IN WITNESS WHEREOF the parties hereto, by and through their duly authorized representatives, have executed this Agreement on behalf of the corporate entities identified herein, on the date first written above.

Sandusky Renaissance Properties, LLC
an Ohio limited liability company

By: _____
TITLE:

By: _____
TITLE:

By: _____
TITLE:

CITY OF SANDUSKY, OHIO

By: _____
City Manager

The legal form of the within instrument
Is hereby approved.

Director of Law
City of Sandusky

CERTIFICATE OF DIRECTOR OF FINANCE

The undersigned, fiscal officer of the City of Sandusky, Ohio, hereby certifies that the money required to meet the obligations of the City during the year 2016 under the foregoing Agreement has been lawfully appropriated by the City Commission of the City for such purposes and are in the treasury of the City or in the process of collection to the credit of an appropriate fund, free from any previous encumbrances. This Certificate is given in compliance with Sections 5705.41 and 5705.44, Ohio Revised Code.

Director of Finance

DRAFT



City of Sandusky Department of Planning and Development
222 Meigs Street, Sandusky, OH 44870
(419) 627-5715

TO: Eric Wobser, City Manager

FROM: Angela Byington, AICP
Planning Director

DATE: May 13, 2016

SUBJECT: Commission Agenda Item – CDBG FY15 Residential Demolition Project #4

ITEM FOR CONSIDERATION: Ordinance authorizing and directing the City Manager to enter into a contract for asbestos abatement and demolition of 533 Taylor Street, 1129 Parish Street and 3709 Linden Street. All properties are vacant, blighted and were ordered for demolition. Liens will be placed on all privately owned properties for the cost of asbestos abatement and demolition.

The following bids were received on May 13, 2016:

Barnes Inc.	Huron, Ohio	\$30,200.00	10% Cashier Check
Ed Burdue & Co., LLC	Sandusky, OH	\$25,000.00	100% Bond
Premier Concrete	Norwalk, Ohio	\$22,200.00	100% Bond
Master Renovations	Orville, Ohio	\$24,150.00	100% Bond

Premier Concrete of Norwalk, Ohio was determined to be the lowest and best bid.

BUDGETARY INFORMATION: The project cost based on the bid, including advertisement and miscellaneous costs is \$22,400. This project will be paid with FY2015 Community Development Block Grant (CDBG) Funds.

ACTION REQUESTED: It is requested that the Ordinance awarding a contract to Premier Concrete of Norwalk, Ohio for the demolition 533 Taylor Street, 1129 Parish Street and 3709 Linden Street in the amount of \$22,200.00 be approved. It is requested that the legislation be passed under suspension of the rules in accordance with Section 14 of the City Charter in order to move forward with the project and eliminate potential hazards from our neighborhoods. These properties have been an issue for many neighbors over the years.

Angela Byington, AICP , Planning Director

I concur with this recommendation:

Eric Wobser, City Manager

ORDINANCE NO. _____

AN ORDINANCE AUTHORIZING AND DIRECTING THE CITY MANAGER TO ENTER INTO A CONTRACT WITH PREMIER CONCRETE OF NORWALK, OHIO, FOR THE CDBG FY15 RESIDENTIAL DEMOLITION PROJECT #4; AND DECLARING THAT THIS ORDINANCE SHALL TAKE IMMEDIATE EFFECT IN ACCORDANCE WITH SECTION 14 OF THE CITY CHARTER.

WHEREAS, this City Commission declared the necessity for the City to proceed with the proposed CDBG FY15 Residential Demolition Project #4 by Resolution No. 022-16R, passed on April 25, 2016; and

WHEREAS, the CDBG FY15 Residential Demolition Project #4 involves asbestos abatement and demolition of three (3) residential structures, which are vacant and blighted, and were condemned and ordered for demolition by the Housing Appeals Board and the three (3) properties are listed as follows: 533 Taylor Street, 1129 Parish Street, and 3709 Linden Street; and

WHEREAS, upon competitive bidding as required by law four (4) appropriate bids were received and the bid from Premier Concrete of Norwalk, Ohio, was determined to be the lowest and best bid; and

WHEREAS, the total cost of the project based on bids and including advertisement and miscellaneous costs is \$22,400.00, and will be paid with Community Development Block Grant (CDBG) funds; and

WHEREAS, this Ordinance should be passed as an emergency measure under suspension of the rules in accordance with Section 14 of the City Charter in order to move forward with the demolition of these properties and eliminate potential hazards from City neighborhoods; and

WHEREAS, in that it is deemed necessary in order to provide for the immediate preservation of the public peace, property, health, and safety of the City of Sandusky, Ohio, and its citizens, and to provide for the efficient daily operation of the Municipal Departments, including the Department of Community Development, of the City of Sandusky, Ohio, the City Commission of the City of Sandusky, Ohio finds that an emergency exists regarding the aforesaid, and that it is advisable that this **Ordinance** be declared an emergency measure which will take immediate effect in accordance with Section 14 of the City Charter upon its adoption; and NOW, THEREFORE,

BE IT ORDAINED BY THE CITY COMMISSION OF THE CITY OF SANDUSKY, OHIO, THAT:

Section 1. The City Manager is authorized and directed to enter into a contract with Premier Concrete of Norwalk, Ohio, for the CDBG FY15 Residential Demolition Project #4, in an amount **not to exceed** Twenty Two Thousand Two Hundred and 00/100 Dollars (\$22,200.00) consistent with the bid submitted by Premier Concrete of Norwalk, Ohio, currently on file in the office of the Director of Public Works.

Section 2. If any section, phrase, sentence, or portion of this Ordinance is for any reason held invalid or unconstitutional by any Court of competent jurisdiction, such portion shall be deemed a separate, distinct, and independent provision, and such holding shall not affect the validity of the remaining portions thereof.

Section 3. This City Commission finds and determines that all formal actions of this City

Commission concerning and relating to the passage of this Ordinance were taken in an open meeting of this City Commission and that all deliberations of this City Commission and of any of its committees that resulted in those formal actions were in meetings open to the public in compliance with the law.

Section 4. That for the reasons set forth in the preamble hereto, this Ordinance is hereby declared to be an emergency measure which shall take immediate effect in accordance with Section 14 of the City Charter after its adoption and due authentication by the President and the Clerk of the City Commission of the City of Sandusky, Ohio.

DENNIS E. MURRAY, JR.
PRESIDENT OF THE CITY COMMISSION

ATTEST: _____
KELLY L. KRESSER
CLERK OF THE CITY COMMISSION

Passed: May 23, 2016



SANDUSKY POLICE DEPARTMENT

JOHN ORZECH, POLICE CHIEF

222 MEIGS STREET
SANDUSKY, OH 44870
Phone: 419.627.5869
FAX: 419.627.5862

Website: www.ci.sandusky.oh.us
Facebook: www.facebook.com/sanduskypolice

TO: Eric Wobser, City Manager
FROM: Chief John Orzech
DATE: 05/11/2016
RE: Commission Agenda Item

ITEM FOR CONSIDERATION:

Legislation approving the submission of a grant application to the FY2016 Edward Byrne memorial Justice Assistance Grant (JAG), through the Office of Criminal Justice Services (OCJS), a division of the Ohio Department of Public Safety for the purchase of a L-3 Flashback HD cruiser video system and accessories for our second K-9 vehicle, with all the needed accessories and extended warranty for the Sandusky Police Department and authorizing the City Manager to enter into any grant agreements and accept funds if awarded.

BACKGROUND INFORMATION:

The City of Sandusky Police Department (S.P.D.) has two (2) K-9 vehicles only one of which has an L-3 Flashback HD cruiser video system installed in it.

BUDGETARY INFORMATION:

The total cost for a new L-3 Flashback HD digital cruiser video system and accessories is \$6,636.28. The grant will fund \$4,977.21 (75%) and the matching funds of \$1,659.07 (25%) will be paid with funds from the Police Department's operating budget. Due to the effects of the economy, the match portion may be waived and a request for a waiver for the match will be submitted with the application.

ACTION REQUESTED:

It is requested that legislation be prepared for the approval of the submission of the grant application to the Office of Criminal Justice Services for the purchase of one (1) new L-3 Flashback HD digital cruiser video system and accessories for the second Sandusky Police Department K-9 vehicle and if awarded, to execute any required agreements and expend funds consistent to the agreements. It is further requested that this be passed in accordance with Section 14 of the City Charter in order to submit grant application prior to the deadline of 06/01/16.

SANDUSKY, OHIO – HOME OF 'AMERICA'S ROLLER COAST'®

John Orzech
Chief of Police

I concur with this recommendation:

Eric Wobser-City Manager

RESOLUTION NO. _____

A RESOLUTION APPROVING THE SUBMISSION OF A GRANT APPLICATION TO THE OHIO OFFICE OF CRIMINAL JUSTICE SERVICES (OCJS) FOR FUNDING THROUGH THE FY 2016 EDWARD BYRNE MEMORIAL JUSTICE ASSISTANCE GRANT (JAG) PROGRAM FOR THE SANDUSKY POLICE DEPARTMENT; AND DECLARING THAT THIS RESOLUTION SHALL TAKE IMMEDIATE EFFECT IN ACCORDANCE WITH SECTION 14 OF THE CITY CHARTER.

WHEREAS, the Ohio Office of Criminal Justice Services (OCJS) is a division of the Ohio Department of Public Safety and by statute is the lead justice planning and assistance office for the State, administering millions of dollars in State and Federal criminal justice funding every year and the OCJS also evaluates programs and develops technology, training and products for criminal justice professionals and communities and has been designated by the Governor to administer the FY 2016 Edward Byrne Memorial Justice Assistance Grant (JAG) program; and

WHEREAS, the Sandusky Police Department has two (2) K-9 vehicles of which only one (1) has an L-3 Flashback HD cruiser video system and desires to purchase another system for the second K-9 vehicle; and

WHEREAS, the total cost to purchase the L-3 Flashback HD cruiser video system and accessories for the K-9 vehicle is \$6,636.28 and if awarded, \$4,977.21 (75%) will be paid with grant funds and the remaining balance of \$1,659.07 (25%) will be paid with funds from the Police Department's operating budget; a match waiver request will be submitted with the application; and

WHEREAS, this Resolution should be passed as an emergency measure under suspension of the rules in accordance with Section 14 of the City Charter in order to submit the grant application to the Ohio Office Of Criminal Justice Services (OCJS) for funding through the Edward Byrne Memorial Justice Assistance Grant (JAG) Program prior to the submission deadline of June 1, 2016; and

WHEREAS, in that it is deemed necessary in order to provide for the immediate preservation of the public peace, property, health, and safety of the City of Sandusky, Ohio, and its citizens, and to provide for the efficient daily operation of the Municipal Departments, including the Police Department of the City of Sandusky, Ohio, the City Commission of the City of Sandusky, Ohio, finds that an emergency exists regarding the aforesaid, and that it is advisable that this **Resolution** be declared an emergency measure which will take immediate effect in accordance with Section 14 of the City Charter; and **NOW, THEREFORE**

BE IT RESOLVED BY THE CITY COMMISSION OF THE CITY OF SANDUSKY, OHIO, THAT:

Section 1. This City Commission hereby approves the submission of a grant application to the Ohio Office Of Criminal Justice Services (OCJS), a copy of which is on file in the Sandusky Police Department, for funding through the FY 2016 Edward Byrne Memorial Justice Assistance Grant (JAG) Program for the purchase of L-3 Flashback HD cruiser video system and accessories for a K-9 vehicle for the Sandusky Police Department and authorizes and directs the City Manager to execute any grant agreements and lawfully expend funds consistent with the application should they be awarded.

Section 2. If any section, phrase, sentence, or portion of this Resolution is for any reason held invalid or unconstitutional by any Court of competent jurisdiction, such portion

shall be deemed a separate, distinct, and independent provision, and such holding shall not affect the validity of the remaining portions thereof.

Section 3. This City Commission finds and determines that all formal actions of this City Commission concerning and relating to the passage of this Resolution were taken in an open meeting of this City Commission and that all deliberations of this City Commission and of any of its committees that resulted in those formal actions were in meetings open to the public in compliance with the law.

Section 4. That for the reasons set forth in the preamble hereto, this Resolution is hereby declared to be an emergency measure which shall take immediate effect in accordance with Section 14 of the City Charter after its adoption and due authentication by the President and the Clerk of the City Commission of the City of Sandusky, Ohio.

DENNIS E. MURRAY, JR.
PRESIDENT OF THE CITY COMMISSION

ATTEST:

KELLY L. KRESSER
CLERK OF THE CITY COMMISSION

Passed: May 23, 2015

**NOTICE TO LEGISLATIVE
AUTHORITY**

OHIO DIVISION OF LIQUOR CONTROL
 8606 TUSSING ROAD, P.O. BOX 4005
 REYNOLDSBURG, OHIO 43068-9005
 (614)644-2360 FAX(614)644-3166

TO

2519620		NEW		MCGOOKEY PROPERTIES LLC DBA BAITHOUSE BREW PUB 215 MEIGS ST SANDUSKY OH 44870
PERMIT NUMBER		TYPE		
ISSUE DATE				
05 06 2016				
FILING DATE				
PERMIT CLASSES				
22	077	B	B20830	
TAX DISTRICT			RECEIPT NO.	



FROM **05/12/2016**

PERMIT NUMBER		TYPE	
ISSUE DATE			
FILING DATE			
PERMIT CLASSES			
TAX DISTRICT			RECEIPT NO.



MAILED **05/12/2016**

RESPONSES MUST BE POSTMARKED NO LATER THAN. **06/13/2016**

IMPORTANT NOTICE

PLEASE COMPLETE AND RETURN THIS FORM TO THE DIVISION OF LIQUOR CONTROL
WHETHER OR NOT THERE IS A REQUEST FOR A HEARING.

REFER TO THIS NUMBER IN ALL INQUIRIES **B NEW 2519620**

(TRANSACTION & NUMBER)

(MUST MARK ONE OF THE FOLLOWING)

WE REQUEST A HEARING ON THE ADVISABILITY OF ISSUING THE PERMIT AND REQUEST THAT
 THE HEARING BE HELD IN OUR COUNTY SEAT. IN COLUMBUS.

WE DO NOT REQUEST A HEARING.

DID YOU MARK A BOX? IF NOT, THIS WILL BE CONSIDERED A LATE RESPONSE.

PLEASE SIGN BELOW AND MARK THE APPROPRIATE BOX INDICATING YOUR TITLE:

(Signature)

(Title)- Clerk of County Commissioner

(Date)

Clerk of City Council

Township Fiscal Officer

CLERK OF SANDUSKY CITY COUNCIL
222 MEIGS STREET
SANDUSKY OHIO 44870

2519620 PERMIT NBR
MCGOOKEY PROPERTIES LLC
DBA BAITHOUSE BREW PUB
215 MEIGS ST
SANDUSKY OH 44870

DANIEL L MCGOOKEY

05/10/2016 ACTIVE

MNMB5%V5%M

PA2-KEY = END SESSION, CLEAR-KEY = END OPTION, ENTER-KEY = TO CONTINUE

OHIO DEPARTMENT OF COMMERCE-DIVISION OF LIQUOR CONTROL

6606 Tussing Road, P.O. Box 4005,
Reynoldsburg, Ohio 43068-9005 Ph (614) 644-2360

INSTITUTION NOTICE FOR LIQUOR PERMIT

Name of Institution To: CONTROLLING AUTHORITY
BATTERY PARK
701 E. WATER ST
SANDUSKY, OHIO 44870

Type of Application Re: NEW D5J
Application Number 2519620
Applicant Name MCGOOKEY PROPERTIES LLC
DBA: BAITHOUSE BREW PUB
Address: 215 MEIGS ST
Address: SANDUSKY, OHIO 44870

Dear Institution Representative:

Approximate Distance 75 Feet

A liquor permit has been applied for at the above captioned location. The Division of Liquor Control is required to notify any church, school, library, public playground, or township park that is located within 500 feet of a proposed permit premises. Your institution, as well as the local legislative authority, is being given the opportunity to object to the issuance of this permit. This is your opportunity to object to the above referenced permit application.

Please complete and return this form no later than 30 days from the date of this notice. Include the name, title, address and telephone number of the representative of the institution who is to attend the hearing. If an objection is filed and a hearing is scheduled, your representative should appear and testify in support of the objection. Otherwise the objection will be overruled. Objections based solely upon philosophical opposition to alcohol consumption are not sufficient grounds for sustaining an objection. You may wish to retain legal counsel to represent your interests, as the hearing is a legal proceeding.

PLEASE CHECK THE APPLICABLE BOX AND RETURN THIS FORM WITHIN 30 DAYS

- We do not object to this Permit.
- We request the Division of Liquor Control document our objection to the issuance of this permit but we do not request a hearing. In choosing this option I understand that it is only an objection for the record and will not adversely impact the issuance of this permit.
- We object and request a hearing on the advisability of issuing of this permit. Please hold the hearing in Columbus.
- We object and request a hearing on the advisability of issuing of this permit. Please hold the hearing in the county seat of the premises.

(Signature of Authority in Control of Institution)	(Telephone Number)	(Date)
(Name, Title of Person to Attend Hearing)	(Address)	

CERTIFICATE OF SERVICE

The above notice was served to CONTROLLING AUTHORITY 322 Meigs St, Sandusky
(Name) (Address)
419-627-5850, the authority in control of subject institution on 5/18/16 by
(Telephone) (Date)

CERTIFIED MAIL, RETURN RECEIPT REQUESTED or PERSONAL SERVICE or STOREFRONT

(Signature and Title of Recipient) KELLY K... 2PM	(Compliance Officer, Unit #, Date) KRISTEN HENSLEY #640
(Print Name and Title of Recipient) KELLY K... Commission Clerk	CERTIFIED MAIL #

Kelly Kresser

From: John Orzech
Sent: Monday, May 16, 2016 8:36 AM
To: Kelly Kresser
Subject: RE: Liquor Permit

No issues with police

JOHN ORZECH | *Chief of Police*
SANDUSKY POLICE DEPT.
222 MEIGS STREET | SANDUSKY, OH 44870
DESK (419) 627-5869 | FAX (419)627-5862



From: Kelly Kresser
Sent: Monday, May 16, 2016 8:14 AM
To: John Orzech <JOrzech@ci.sandusky.oh.us>; Stephen Rucker <srucker@ci.sandusky.oh.us>; Casey Sparks <csparks@ci.sandusky.oh.us>
Subject: Liquor Permit

Attached is a request for a new D5J (Spirituos liquor for on premises consumption only, beer, wine and mixed beverages for on premises, or off premises in original sealed containers, until 2:30am. In a community entertainment district) liquor permit for McGookey Properties, 215 Meigs Street.

Please provide comments to me by Wednesday so this can make next Monday's Agenda.



Kelly Kresser, CMC
City Commission Clerk
222 Meigs Street
Sandusky, OH 44870

419.627.5850

www.ci.sandusky.oh.us

From: Stephen Rucker
Sent: Monday, May 16, 2016 1:28 PM
To: Kelly Kresser; John Orzech; Casey Sparks
Subject: Re: Liquor Permit

No issues from my office
Get Outlook for Android

On Mon, May 16, 2016 at 5:14 AM -0700, "Kelly Kresser" <kkresser@ci.sandusky.oh.us>
wrote:

Attached is a request for a new D5J (Spirituous liquor for on premises consumption only, beer, wine and mixed beverages for on premises, or off premises in original sealed containers, until 2:30am. In a community entertainment district) liquor permit for McGookey Properties, 215 Meigs Street.

Please provide comments to me by Wednesday so this can make next Monday's Agenda.

Kelly Kresser, CMC
City Commission Clerk
222 Meigs Street
Sandusky, OH 44870

419.627.5850
www.ci.sandusky.oh.us

Kelly Kresser

From: Casey Sparks
Sent: Wednesday, May 18, 2016 3:17 PM
To: Kelly Kresser
Subject: RE: Liquor Permit

Kelly,

The property is zoned as Downtown Business District which permits the sale of beer and wine. Please let me know if you have any questions or concerns.

Thank you,

Casey Sparks
Assistant Planner
City of Sandusky
222 Meigs Street
Sandusky, Ohio 44870
419-627-5715

From: Kelly Kresser
Sent: Monday, May 16, 2016 8:14 AM
To: John Orzech <JOrzech@ci.sandusky.oh.us>; Stephen Rucker <srucker@ci.sandusky.oh.us>; Casey Sparks <csparks@ci.sandusky.oh.us>
Subject: Liquor Permit

Attached is a request for a new D5J (Spirituous liquor for on premises consumption only, beer, wine and mixed beverages for on premises, or off premises in original sealed containers, until 2:30am. In a community entertainment district) liquor permit for McGookey Properties, 215 Meigs Street.

Please provide comments to me by Wednesday so this can make next Monday's Agenda.



Kelly Kresser, CMC
City Commission Clerk
222 Meigs Street
Sandusky, OH 44870

419.627.5850
www.ci.sandusky.oh.us

**NOTICE TO LEGISLATIVE
AUTHORITY**

OHIO DIVISION OF LIQUOR CONTROL
6606 TUSSING ROAD, P.O. BOX 4005
REYNOLDSBURG, OHIO 43068-9005
(614)644-2360 FAX(614)644-3166

TO

4235201		NEW		JAMI S TALLMAN LTD LLC DBA SCARLETT O HAIR SALON 123-125 W MARKET ST SANDUSKY OH 44870	
PERMIT NUMBER		TYPE			
05 12 2016					
ISSUE DATE		FILING DATE			
D5J		PERMIT CLASSES			
22	077	B	B21292		
TAX DISTRICT		RECEIPT NO			

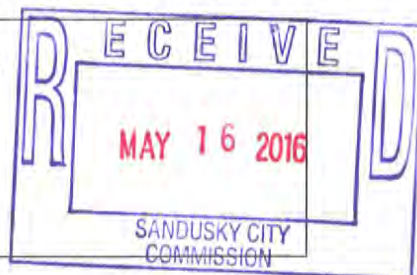

FROM 05/16/2016

PERMIT NUMBER		TYPE	
ISSUE DATE		FILING DATE	
PERMIT CLASSES			
TAX DISTRICT	RECEIPT NO		



MAILED 05/16/2016

RESPONSES MUST BE POSTMARKED NO LATER THAN.

06/16/2016

IMPORTANT NOTICE

PLEASE COMPLETE AND RETURN THIS FORM TO THE DIVISION OF LIQUOR CONTROL
WHETHER OR NOT THERE IS A REQUEST FOR A HEARING.

REFER TO THIS NUMBER IN ALL INQUIRIES

B NEW 4235201

(TRANSACTION & NUMBER)

(MUST MARK ONE OF THE FOLLOWING)

WE REQUEST A HEARING ON THE ADVISABILITY OF ISSUING THE PERMIT AND REQUEST THAT
THE HEARING BE HELD IN OUR COUNTY SEAT. IN COLUMBUS.

WE DO NOT REQUEST A HEARING.

DID YOU MARK A BOX? IF NOT, THIS WILL BE CONSIDERED A LATE RESPONSE.

PLEASE SIGN BELOW AND MARK THE APPROPRIATE BOX INDICATING YOUR TITLE:

(Signature)

(Title)- Clerk of County Commissioner

(Date)

Clerk of City Council

Township Fiscal Officer

CLERK OF SANDUSKY CITY COUNCIL
222 MEIGS STREET
SANDUSKY OHIO 44870

4235201 PERMIT NBR
JAMI S TALLMAN LTD LLC
DBA SCARLETT O HAIR SALON
123-125 W MARKET ST
SANDUSKY OH 44870

JAMI S TALLMAN

04/07/2016 ACTIVE

CEO

5% MEMSHIP

PA2-KEY = END SESSION, CLEAR-KEY = END OPTION, ENTER-KEY = TO CONTINUE

Kelly Kresser

From: John Orzech
Sent: Monday, May 16, 2016 9:48 AM
To: Kelly Kresser
Subject: RE: New Liquor Permit

No issues from police

JOHN ORZECH | *Chief of Police*
SANDUSKY POLICE DEPT.
222 MEIGS STREET | SANDUSKY, OH 44870
DESK (419) 627-5869 | FAX (419)627-5862



From: Kelly Kresser
Sent: Monday, May 16, 2016 9:40 AM
To: Stephen Rucker <srucker@ci.sandusky.oh.us>; John Orzech <JOrzech@ci.sandusky.oh.us>; Casey Sparks <csparks@ci.sandusky.oh.us>
Subject: New Liquor Permit

Attached is a request for a new D5J (Spirituos liquor for on premises consumption only, beer, wine and mixed beverages for on premises, or off premises in original sealed containers, until 2:30am. In a community entertainment district) liquor permit for Jami Tallman, dba Scarlett O Hair Salon, 123 – 1125 West Market Street.

Please provide comments to me by Wednesday so this can make next Monday's Agenda.



Kelly Kresser, CMC
City Commission Clerk
222 Meigs Street
Sandusky, OH 44870

419.627.5850
www.ci.sandusky.oh.us

Kelly Kresser

From: Stephen Rucker
Sent: Monday, May 16, 2016 1:27 PM
To: Kelly Kresser; John Orzech; Casey Sparks
Subject: Re: New Liquor Permit

No issues from my office, thanks

Get [Outlook for Android](#)

On Mon, May 16, 2016 at 6:40 AM -0700, "Kelly Kresser" <kkresser@ci.sandusky.oh.us> wrote:

Attached is a request for a new D5J (Spirituous liquor for on premises consumption only, beer, wine and mixed beverages for on premises, or off premises in original sealed containers, until 2:30am. In a community entertainment district) liquor permit for Jami Tallman, dba Scarlett O Hair Salon, 123 – 1125 West Market Street.

Please provide comments to me by Wednesday so this can make next Monday's Agenda.



Kelly Kresser, CMC
City Commission Clerk
222 Meigs Street
Sandusky, OH 44870

419.627.5850
www.ci.sandusky.oh.us

Kelly Kresser

From: Casey Sparks
Sent: Wednesday, May 18, 2016 3:17 PM
To: Kelly Kresser
Subject: RE: New Liquor Permit

Kelly,

The property is zoned as Downtown Business District which permits the sale of beer and wine. Please let me know if you have any questions or concerns.

Thank you,

Casey Sparks
Assistant Planner
City of Sandusky
222 Meigs Street
Sandusky, Ohio 44870
419-627-5715

From: Kelly Kresser
Sent: Monday, May 16, 2016 9:40 AM
To: Stephen Rucker <srucker@ci.sandusky.oh.us>; John Orzech <JOrzech@ci.sandusky.oh.us>; Casey Sparks <csparks@ci.sandusky.oh.us>
Subject: New Liquor Permit

Attached is a request for a new D5J (Spirituous liquor for on premises consumption only, beer, wine and mixed beverages for on premises, or off premises in original sealed containers, until 2:30am. In a community entertainment district) liquor permit for Jami Tallman, dba Scarlett O Hair Salon, 123 – 1125 West Market Street.

Please provide comments to me by Wednesday so this can make next Monday's Agenda.



Kelly Kresser, CMC
City Commission Clerk
222 Meigs Street
Sandusky, OH 44870

419.627.5850
www.ci.sandusky.oh.us